METAL SUSPENSION SYSTEMS FOR LAY IN PANEL CEILINGS

IR M-3

Reference: California Building Code, Section 2501A.5

Revised 3-31-00
Supercedes IR 47-4 (6/89)

This interpretation is intended for use by the plan review and field engineers of DSA to indicate an acceptable method for achieving compliance with applicable codes and regulations. Its purpose is to promote more uniform statewide criteria for use in plan review and supervision of construction of public schools, community colleges and essential services buildings. Other methods proposed by design professionals to solve a particular problem may be considered by DSA and reviewed for code and regulation compliance.

Purpose: The purpose of this IR is to provide guidelines for the installation of metal suspension systems for lay in ceilings.

1. Ceiling Notes. The following notes will be acceptable in plans and specifications for ceiling systems whose total weight, including air conditioning grilles and light fixtures, does not exceed four (4) psf. Heavier systems and those supporting lateral loads from partitions, will require special design details.

1.1 12 ga. (min.) hanger wires may be used for up to and including 4'-0" x 4'-0" grid spacing and shall be attached to main runners.

1.2 Provide 12 ga. hanger wires at the ends of all main and cross runners within eight inches (8") of the support or within one-fourth (1/4) of the length of the end tee, whichever is least, for the perimeter of the ceiling area. End connections for runners which are designed and detailed to resist the applied vertical and horizontal forces may be used in lieu of the 12 ga. hanger wires, subject to Division of the State Architect (DSA) review and approval.

1.3 Provide trapeze or other supplementary support members at obstructions to typical hanger spacing. Provide additional hangers, struts or braces as required at all ceiling breaks, soffits or discontinuous areas. Hanger wires that are more than 1 in 6 out of plumb are to have counter-sloping wires.

1.4 Ceiling grid members may be attached to not more than two (2) adjacent walls. Ceiling grid members shall be at least 1/2" free of other walls. If walls run diagonally to ceiling grid system runners, one end of main and cross runners should be free, and a minimum of 1/2" clear of wall.

1.5 At the perimeter of the ceiling area where main or cross runners are not connected to the adjacent wall, provide interconnection between the runners at the free end to prevent lateral spreading. A metal strut or a 16 ga. wire with a positive mechanical connection to the runner may be used. Where the perpendicular distance from the wall to the first parallel runner is 12" or less, this interlock is not required.

1.6 Provide bracing assemblies consisting of a compression strut and four (4) 12 ga. splayed bracing wires oriented 90 degrees from each other (see Figure 1) at the following spacing:

1. For school buildings, place bracing assemblies at a spacing not more than 12' by 12' on center.
2. For Essential Services Buildings, place bracing assemblies not more than 8' by 12' on center.
3. Provide bracing assemblies at locations not more than one half (1/2) the spacings given above, from each perimeter wall and at the edge of vertical ceiling offsets.

The slope of these wires shall not exceed 45 degrees from the plane of the ceiling and shall be taut. Splices in bracing wires are not to be permitted without special DSA approval.

4. Suspended acoustical ceiling systems with a ceiling area of 144 square feet or less, and fire rated suspended acoustical ceiling systems with a ceiling area of 96 square feet or less, surrounded by walls which connect directly to the structure above, do not require bracing assemblies when attached to two adjacent walls.

1.7 Fasten hanger wires with not less than three (3) tight turns. Fasten bracing wires with four (4) tight turns. Make all tight turns within a distance of 1½" inches. Hanger or bracing wire anchors to the structure should be installed in such a manner that the direction of the wire aligns as closely as possible with the direction of the forces acting on the wire.

Note: Wire turns made by machine where both strands have been deformed or bent in wrapping can waive the 1½" requirement, but the number of turns should be maintained, and be as tight as possible.

1.8 Separate all ceiling hanging and bracing wires at least six inches (6") from all unbraced ducts, pipes, conduit, etc. It is acceptable to attach lightweight items, such as single electrical conduit not exceeding 3/4" nominal diameter, to hanger wires using connectors acceptable to DSA.

1.9 When drilled-in concrete anchors or shot-in anchors are used in reinforced concrete for hanger wires, 1 out of 10 must be field tested for 200 lbs. in tension. When drilled-in concrete anchors are used for bracing wires, 1 out of 2 must be field tested for 440 lbs. in tension. Shot-in anchors in concrete are not permitted for bracing wires. If any shot-in or drilled-in anchor fails, see CBC, Section 1923A.3.5.

Note: Drilled-in or shot-in anchors require special DSA approval when used in prestressed concrete.

1.10 Attach all light fixtures and ceiling mounted air terminals or services, to the ceiling grid runners to resist a horizontal force equal to the weight of the fixtures. Screws or approved fasteners are required.

1.11 Flush or recessed light fixtures and air terminals or services, weighing less than 56 lbs., may be supported directly on the runners of a heavy duty grid system but, in addition, they must have a minimum of two 12 ga. slack safety wires attached to the fixture at diagonal corners and anchored to the structure above. All 4' x 4' light fixtures must have slack safety wires at each corner.

All flush or recessed light fixtures and air terminals or services weighing 56 lbs. or more must be independently supported by not less than four (4) taut 12 ga. wires each attached to the fixture and to the structure above regardless of the type of ceiling grid system used.

The four (4) taut 12 ga. Wires including their attachment to the structure above must be capable of supporting four (4) times the weight of the unit.

1.12 All fixtures and air terminals or services supported on intermediate duty grid systems must be independently supported by not less than four (4) taut 12 ga. wires each attached to the fixture or terminal, and to the structure above.

1.13 Support surface mounted light fixtures by at least two positive devices which surround the ceiling runner and which are each supported from the structure above by a 12 ga. wire. Spring clips or clamps that connect only to the runner are not acceptable.

Provide additional supports when light fixtures are 8'-0" or longer.

1.14 Support pendant mounted light fixtures directly from the structure above with hanger wires or cables passing through each pendant hanger and capable of supporting four (4) times the weight of the fixture. A bracing assembly per Figure 1, is required where the pendant hanger penetrates the ceiling. Special details are required to attach the pendant hanger to the bracing assembly to transmit horizontal forces.

1.15 Required notes on construction documents:

Classification of ceiling grid (fill in blanks).

Classification of ceiling grid is ____ (1) ____ duty.

Manufacturer's catalog number - main runner (2) (3) .

Manufacturer's catalog number - cross runner (2) (3) .

Manufacturer's catalog number of detail for runner splice (3) .

(1) Fill in either "intermediate" or "heavy".

(2) Runners must be rated for duty listed.

(3) Show manufacturer, duty classification and catalog numbers. Show light fixture and air terminal or grille support details for grid duty classification selected. See Items 1.11 and 1.12 above.

2. Additional Requirements for Fire Rated Ceilings.

2.1 Provide Underwriter Laboratory (U.L.) design number or State Fire Marshal (SFM) listing number. The components and installation details must conform in every respect with the U.L. or SFM approval for the design number specified. Custom designs which combine components from different approved designs but have not been tested as a complete assembly are not acceptable.

2.2 For schools and Essential Services Buildings, bracing assemblies are required for each 96 square feet. The first bracing assembly is required not more than four feet (4'-0") from each wall. A minimum of one bracing assembly is required between any two adjacent expansion cut-outs on runners being braced.

2.3 Pop rivets, screws, or other attachments are not acceptable unless specifically detailed on the drawings and approved by U.L. and SFM.

3. Additional Requirements for Metal Panels. Metal panels and panels weighing more than 1/2 psf, other than acoustical tile, are to be positively attached to the ceiling suspension runners.

4. Suspended Acoustical Ceilings Below Gypsum Board Ceilings. Where gypsum board or other ceiling finishes are attached to the framing, special details will be required for the vertical hanger wire and lateral bracing wire support connections to the framing.

5. Reuse of Existing Ceiling Hanger Wires and Splay Wires.

5.1 The gage and spacing of the wires must comply with the current applicable codes.

5.2 All existing ceiling hanger wires must be tested to 200 lbs. in tension.

5.3 All existing splayed bracing wires must be field tested to 440 lbs. in tension.

5.4 If a new wire is to be spliced to an existing wire, the following is required:

1. The architect or structural engineer in general responsible charge must submit to DSA a detail and specification describing how the splice is to be made.
2. All new wires, after being spliced to the existing wires, must be field tested per Items 5.2 and 5.3 above.
3. All field tests must be performed in the presence of the project inspector.

6. List of DSA Product Approvals for Suspended Acoustical Ceiling System

**DSA Product
Approval #**

PA-008	Tectum I and Tectum II - Form Board, Acoustical Board and Suspended Ceiling Tile
PA-022	Armstrong Cassettes 800 Series Metal Ceiling System
PA-026	Chicago Metallic Suspended Ceiling System
PA-030	USG Interior Donn Suspended Ceiling Grid Systems
PA-041	Armstrong World Industries Suspended Ceiling System
PA-078	Metaline, Plantostile and Magna T-Cell Suspended Ceiling Systems

Note: Alternate manufacturers and systems may be submitted for review and approved by the Division of the State Architect.

Figure 1
SUSPENDED CEILING BRACING ASSEMBLY

Bracing assemblies are required at spacing indicated in section 1.6 on page 1 of IR 25-2

Compression struts:

Steel section with l/r ratio of 200 maximum. Attach to main runners within 2" of cross runner with 2-#12 self-drilling self-tapping (SDST) screws and to structure with 2-#12 x 2" screws at wood or 3/16" diameter anchor at concrete/steel. Compression strut shall not replace hanger wire.

Note:
 See figures 3,4,5,6 for connections of bracing & hanger wire to the structure above

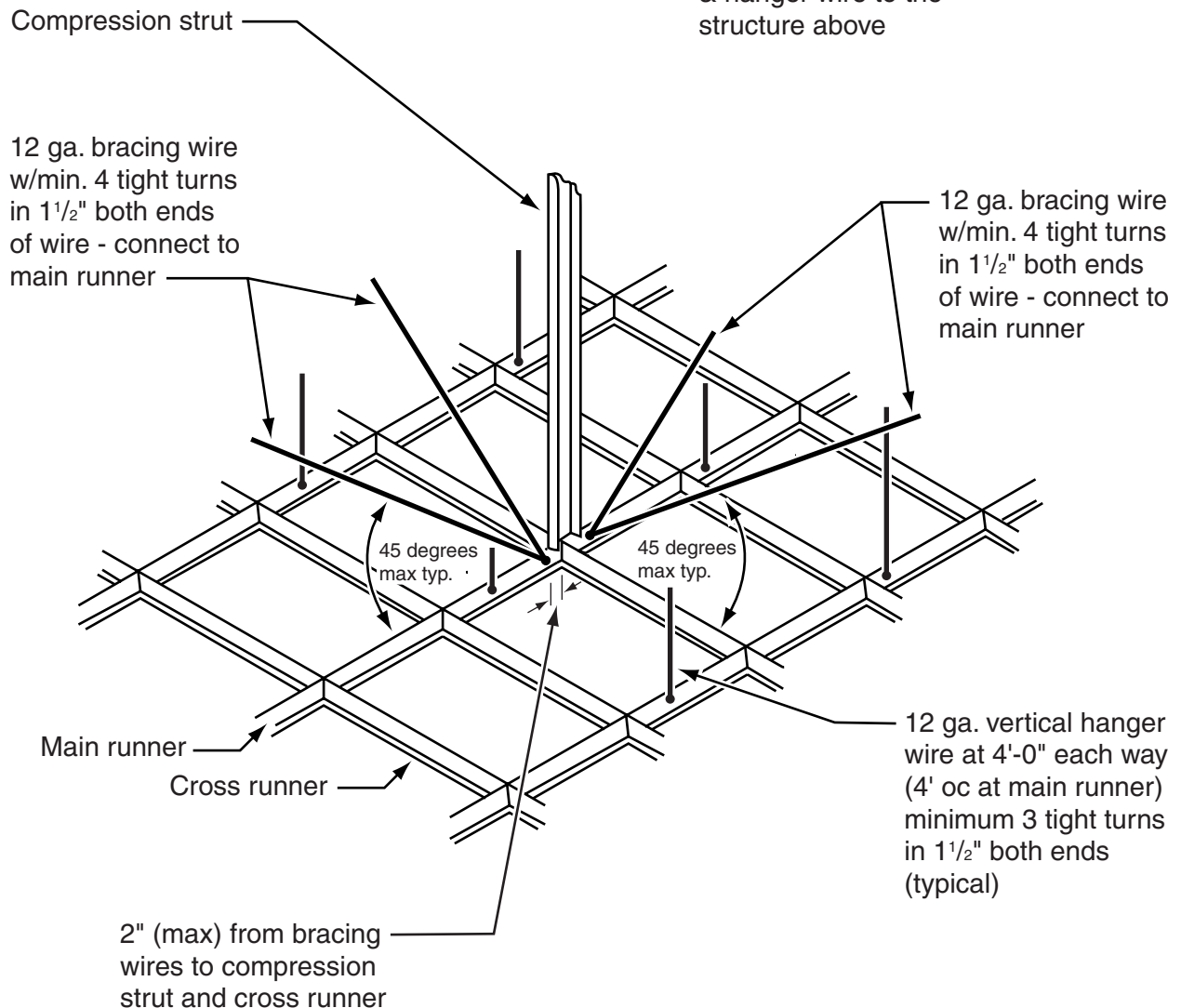
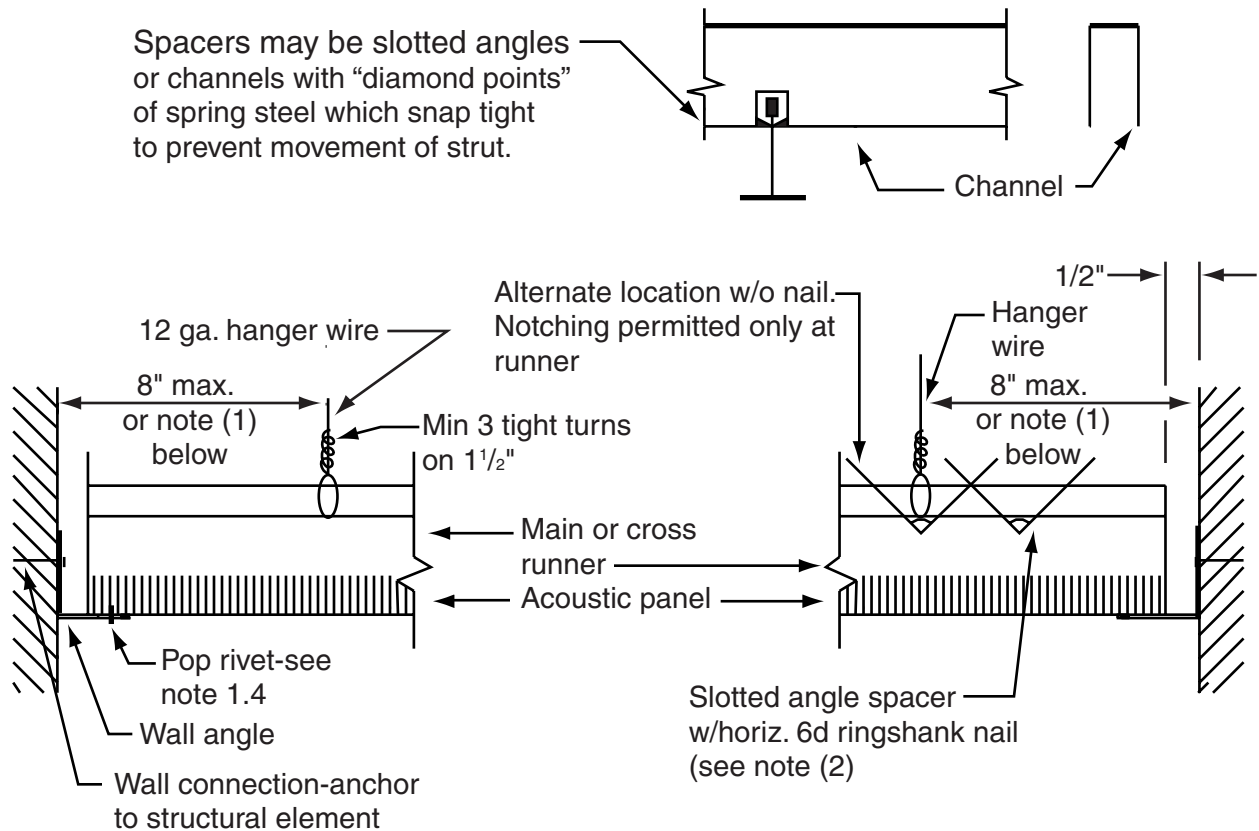
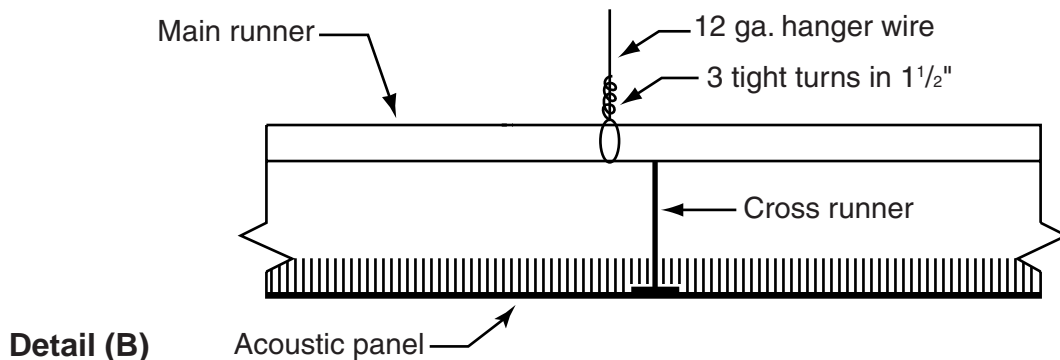

Figure 2
ACCEPTABLE HANGER WIRE CONNECTION TO GRID



Detail (A) Horizontal strut - typical (see note 1.5)

- Notes: (1) 1/4 of the length of the end runner whichever is less.
 (2) Nails at the end of horizontal struts are to be placed with nail head toward centerline of span of strut



Detail (B)

Figure 3A

ACCEPTABLE DETAILS - WIRE CONNECTIONS TO WOOD FRAMING

Three 1½" x 9 ga. staples or 3-stronghold "J" nails at each wire loop

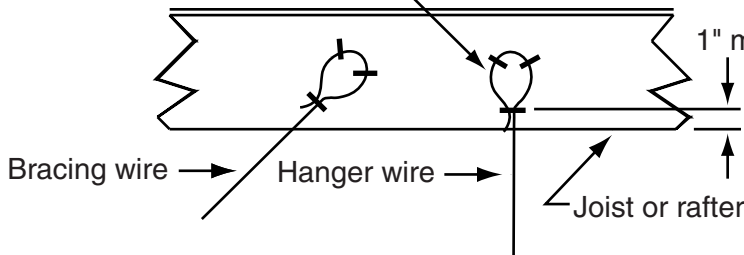

(A) Wood joist or rafter

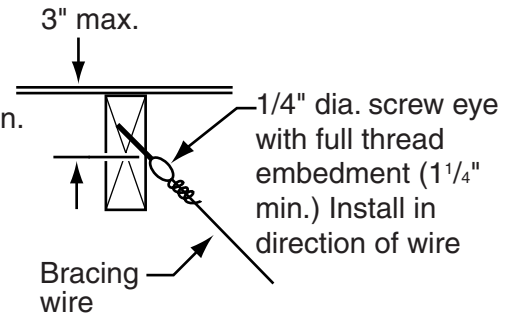

(B) Wood joist or rafter

Three 1½" x 9 ga. staples or three stronghold "J" nails at each wire loop

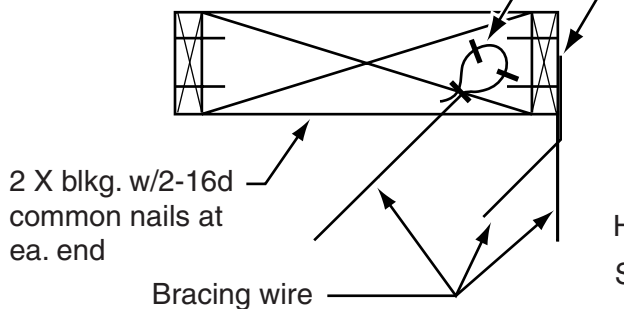

(C) Wood joist or block

For bracing wires - fully embed screw eye threads in direction of wire

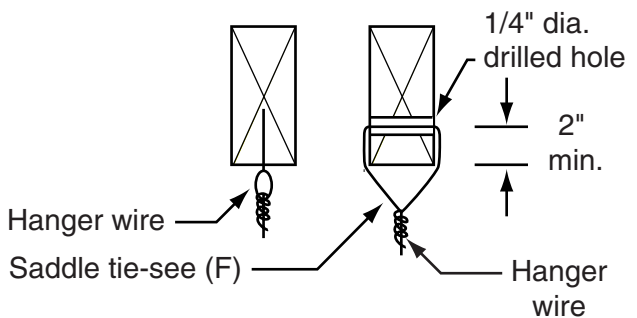

(D) At bottom of joist

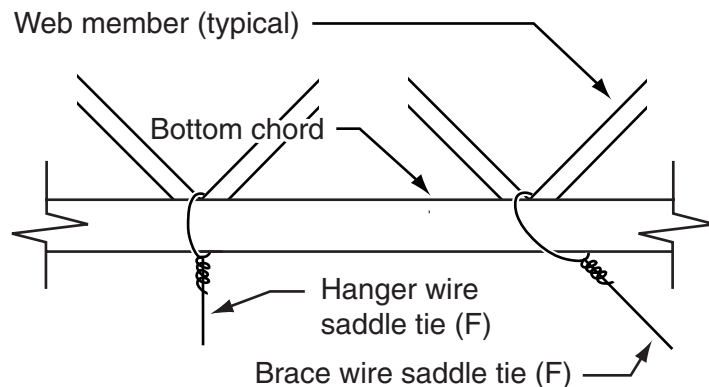

(E) Bracing wire parallel to wood truss

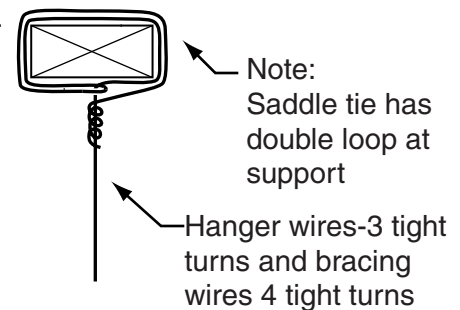

(F) Typ. saddle tie

Figure 3B
ACCEPTABLE DETAILS – WIRE CONNECTION AT WOOD FRAMING

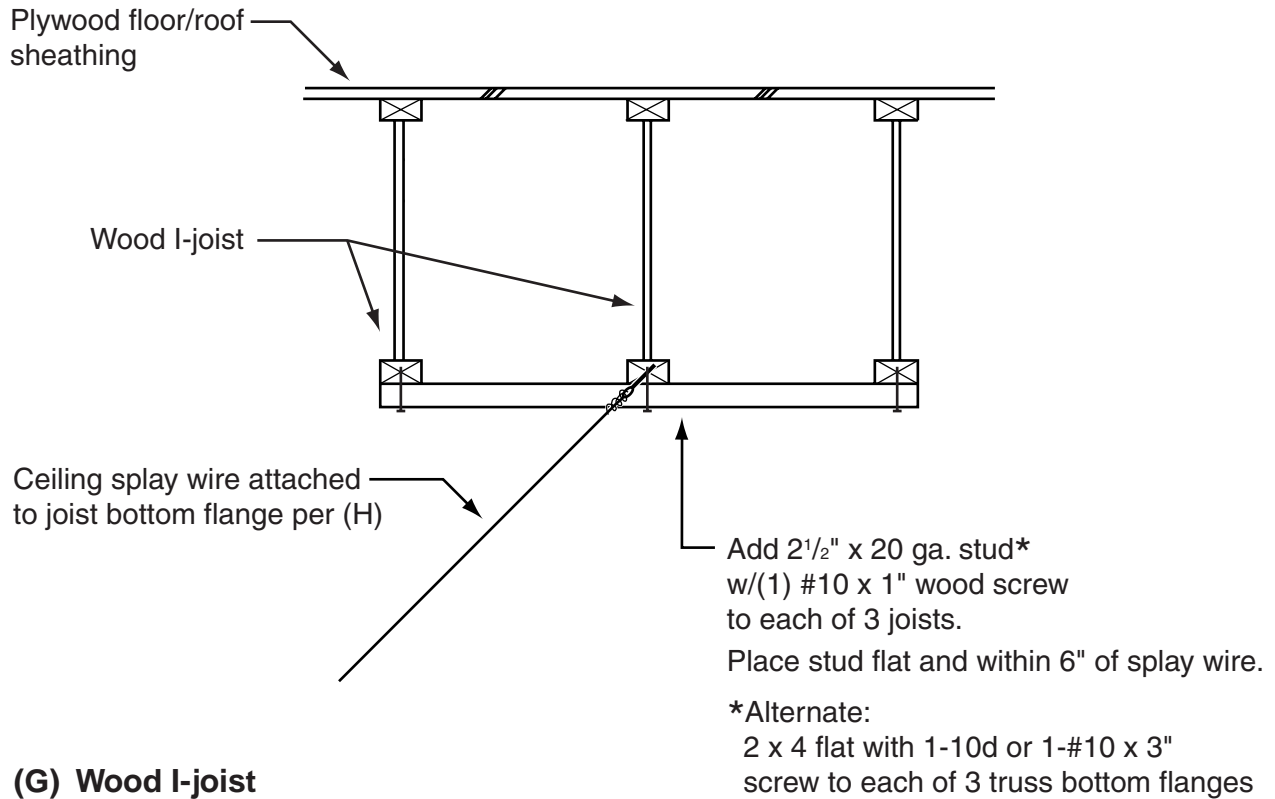

Note: Do not insert screw
 e yes parallel to laminations

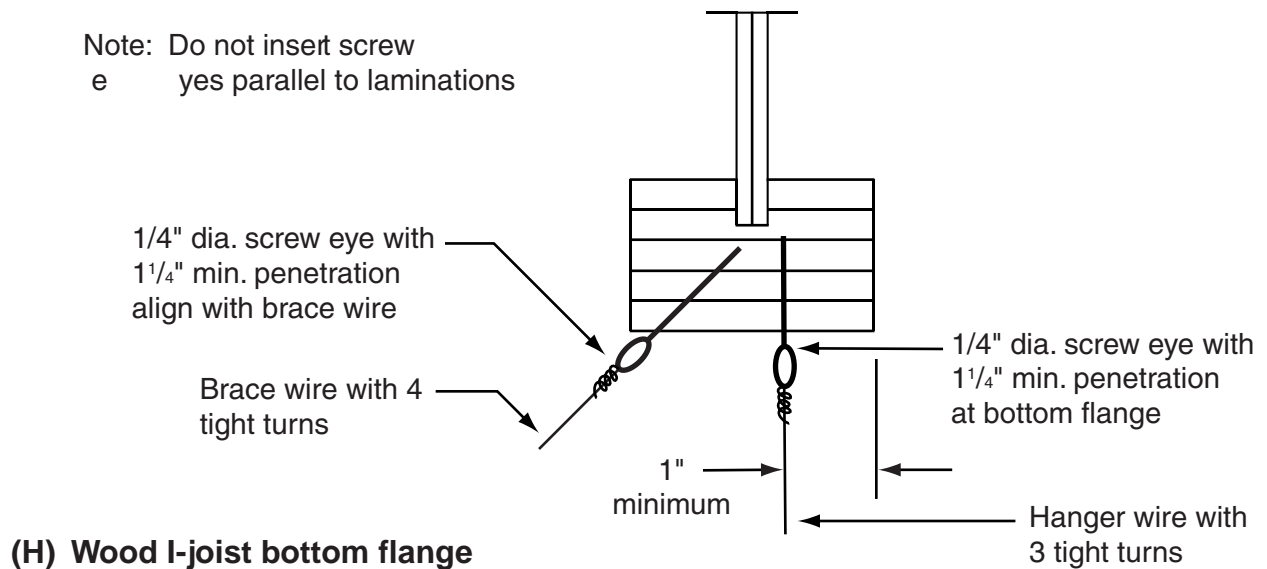
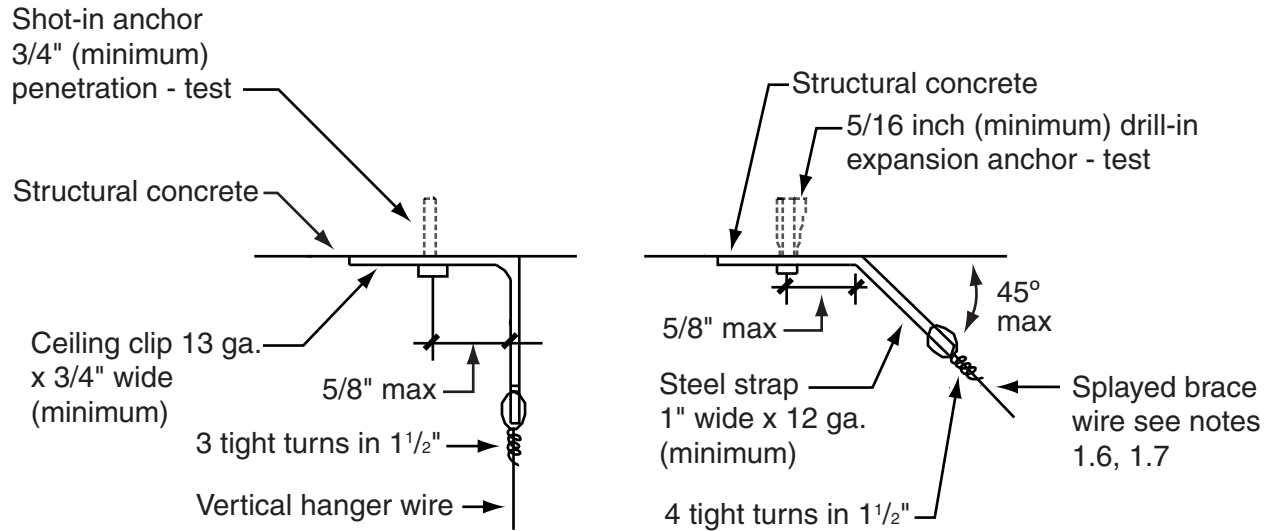
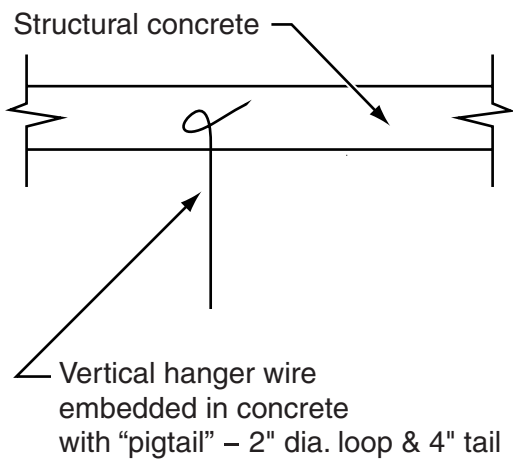

Figure 4

ACCEPTABLE DETAILS - WIRE CONNECTION TO CAST-IN-PLACE CONCRETE



(A) Vertical hanger wire clip attachment (B) Splayed bracing wire clip attachment



(C) Hanger wire at C.I.P. concrete

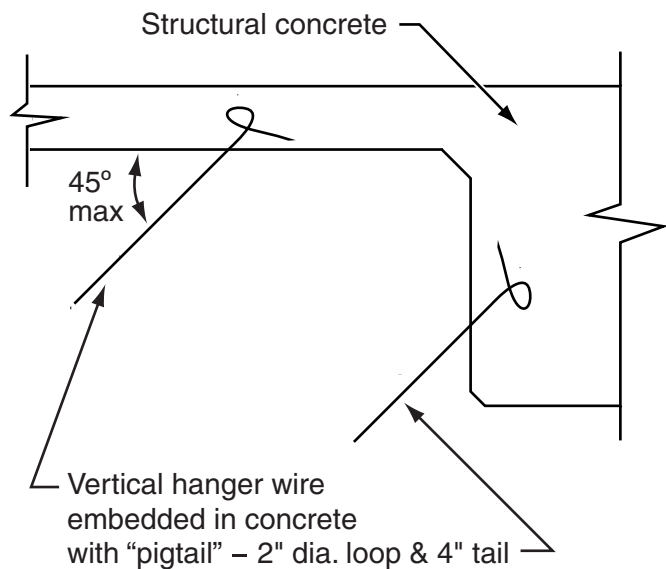

(D) Brace wire at C.I.P. concrete

Figure 5
ACCEPTABLE DETAILS - WIRE CONNECTIONS TO STEEL FRAMING

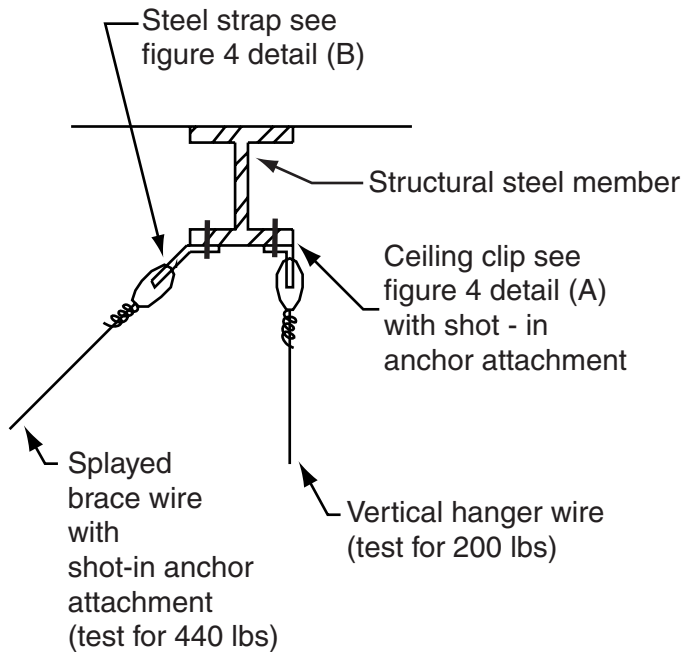

(A) At steel beams

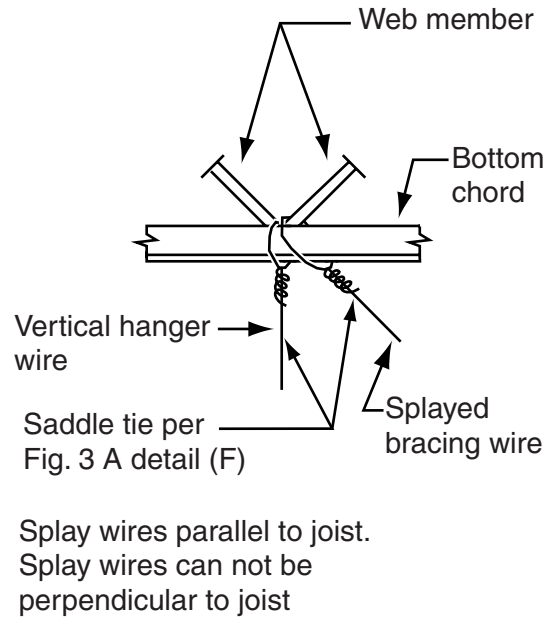

(B) At open-web steel joist

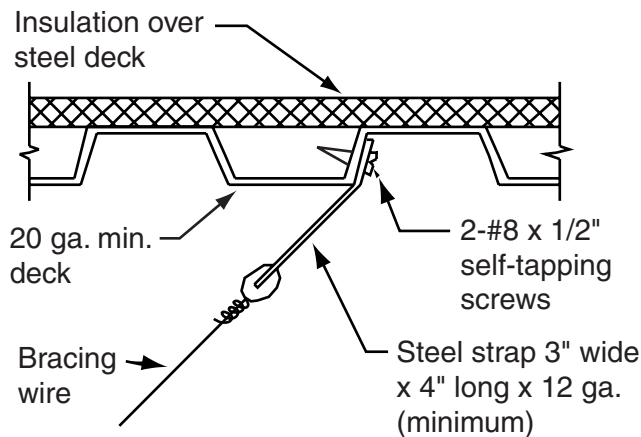

(C) At steel roof deck

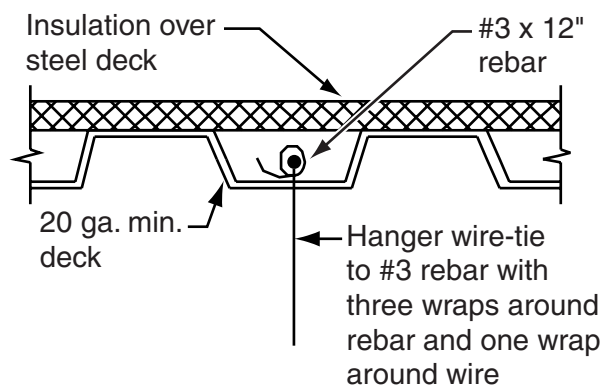

(D) At steel roof deck

Note: If self-tapping screws are used with concrete fill, set screws before placing concrete

Figure 6
ACCEPTABLE DETAILS - WIRE CONNECTIONS TO STEEL FRAMING

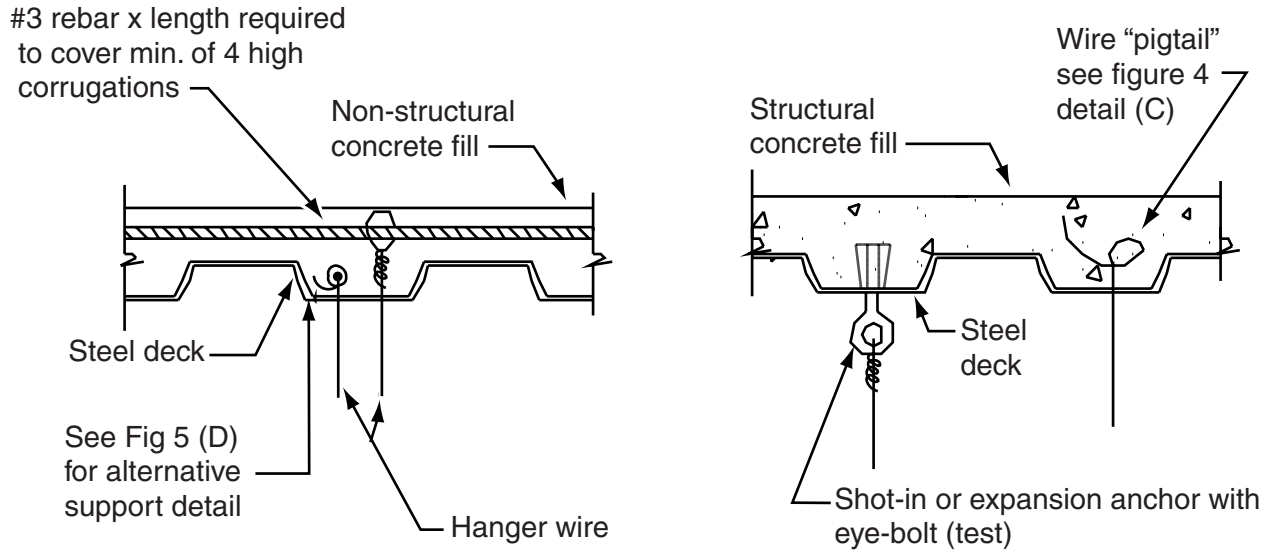

(A) At steel deck with insulation fill

(B) At steel deck with concrete fill

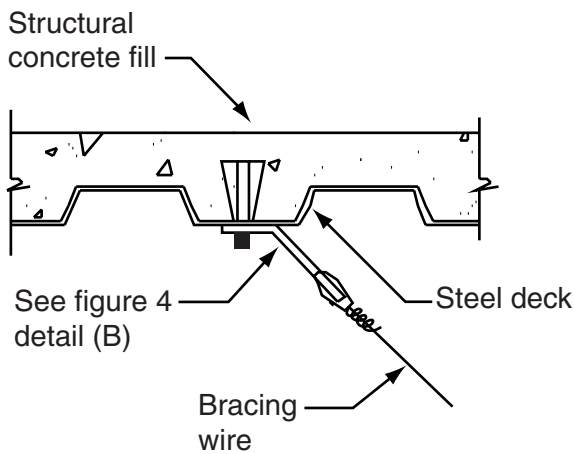

(C) At steel deck with concrete fill

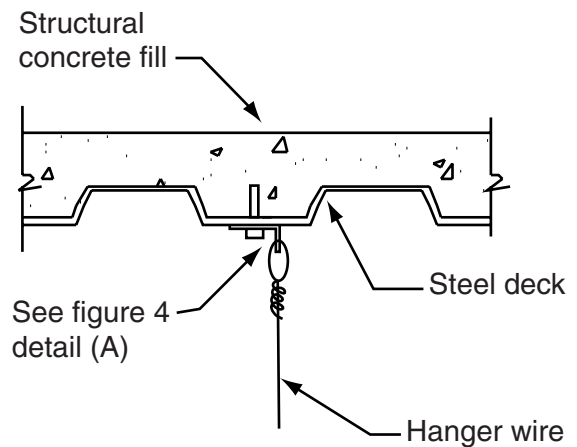

(D) At steel deck with concrete fill

Note: If self tapping screws are used with concrete fill, set screws before placing concrete.

Figure 7
ACCEPTABLE LOCATION OF SLIP JOINTS IN ESB EXITWAYS

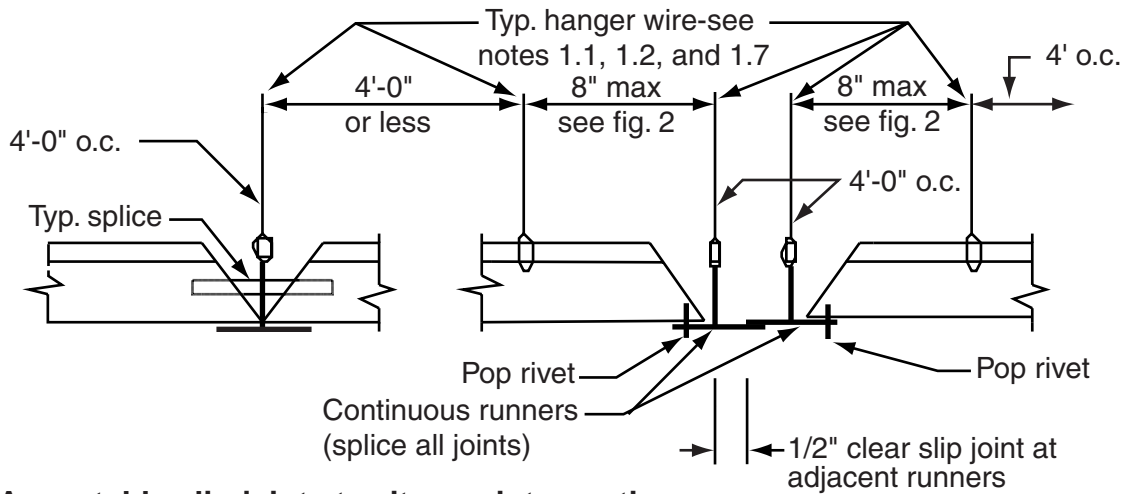

(A) Acceptable slip joint at exitways intersection

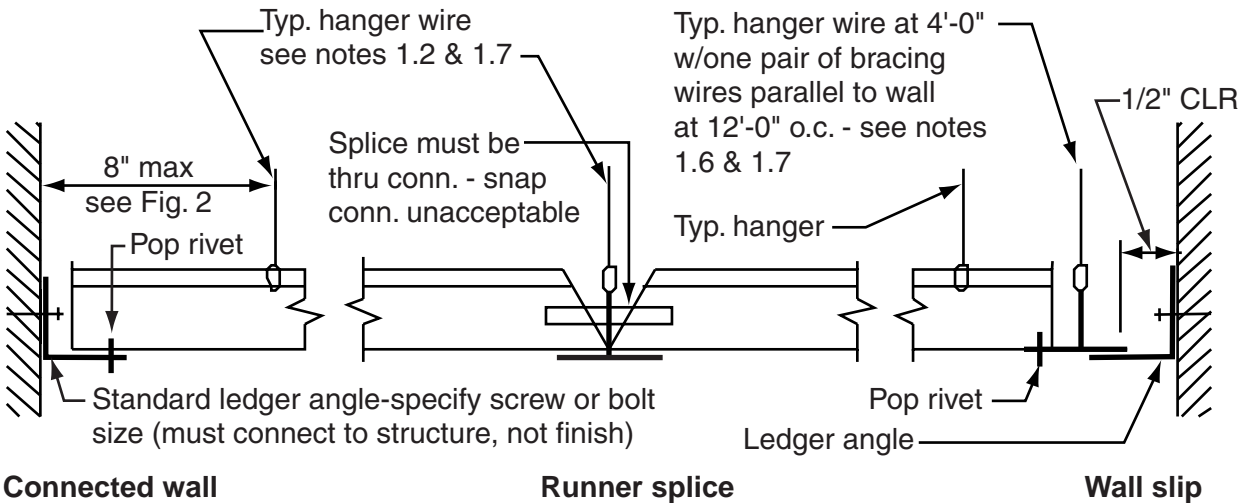

(B) Acceptable exitways details at essential services buildings (ESB)

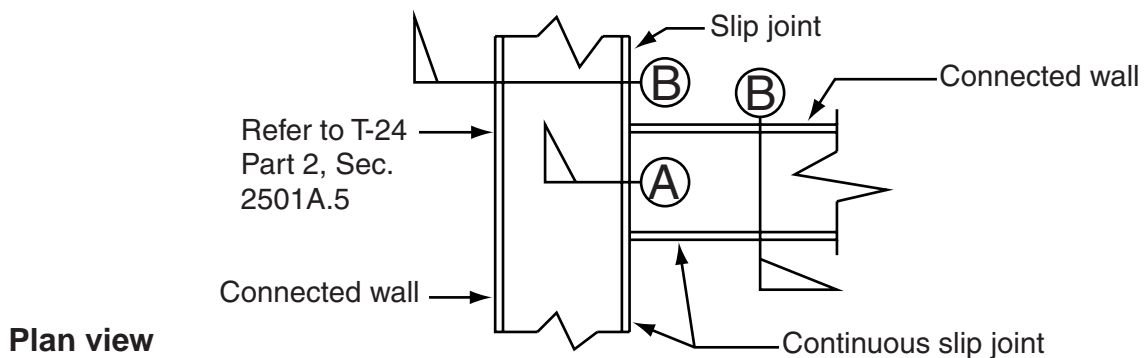

Plan view